



Budowa

Pompy wirowe z pojedynczym wirnikiem zamkniętym. Silnik elektryczny z przedłużonym wałem, na którym osadzony jest wirnik. Korpus pompy z króćcem ssawnym i przyłączami o tej samej średnicy i na tej samej osi (w linii).

Połączenie: Kolnierze PN 10, EN 1092-2.

Przeciwkołnierze (na życzenie)

Rozmiary	Kolnierze
NR, NR4 32, 40, 50, 65	Kolnierze wkręcane PN 16, EN 1092-1
NR4 100, NR4 125	Kolnierze do spawania PN 10, EN 1092-1

5

Zastosowania

- dla cieczy czystych, bez materiałów ściemnych, nieagresywnych dla materiałów pompy (dopuszczalna zawartość ciał stałych: 0,2 %),
- do obiegów wodnych, ciepłych, klimatyzacyjnych i chłodzących,
- do zastosowań przemysłowych i domowych,
- gdy wymagana jest cicha praca (n ≈ 1450 obr/min).

Warunki pracy pompy

Dopuszczalna temperatura cieczy: od -10 °C do +90 °C,
Dopuszczalna temperatura otoczenia: do +40 °C,
Całkowita wysokość ssania: 7 metrów,
Maksymalne dopuszczalne ciśnienie w pompie: 10 barów.
Praca ciągła.

Silnik

Silnik indukcyjny dwubiegunowy, 50 Hz (n ≈ 2900 obr/min).

NR: trójfazowy 230/400 V ± 10% do 3 kW;
400/690 V ± 10% od 4 do 18,5 kW.

NRM: jednofazowy 230 V ± 10%.

Silnik indukcyjny czterobiegunowy, 50 Hz (n ≈ 1450 rpm).

NR4: trójfazowy 230/400 V ± 10% do 3 kW;
400/690 V ± 10% dla 4 kW.

NRM4: jednofazowy 230 V ± 10%.

Klasa izolacji F.

Stopień ochrony IP 54.

Silnik typ IE3 dla silników trójfazowych od 0,75 kW.

Wykonanie zgodnie z normami: EN 60034-1, EN 60034-30,
EN 60335-1, EN 60335-2-41.

Materiały

Wykonanie	Materiał
Obudowa pompy	Żeliwo GJL 200 EN 1561
Łącznik	
Wirnik	Żeliwo GJL 200 EN 1561 (Mosiądz P-Cu Zn Pb 2 EN 1982 dla NR-NR4 32,40,50)
Wał	Stal chromowo - niklowa AISI 303 dla pomp od 1.1 kW Stal chromowa AISI 430 dla pomp od 1.5 do 18,5 kW
Uszczelnienie mech.	Węgiel - Ceramika - NBR
Przeciwkołnierze	Stal Fe 42 UNI 7070

Wykonanie specjalne na życzenie

- Inne wielkości napięcia. - Stopień ochrony IP 55. - Częstotliwość 60 Hz
- Specjalne uszczelnienia mechaniczne.
- Wyższa/niższa temperatura cieczy i otoczenia.

Wykresy sprawności

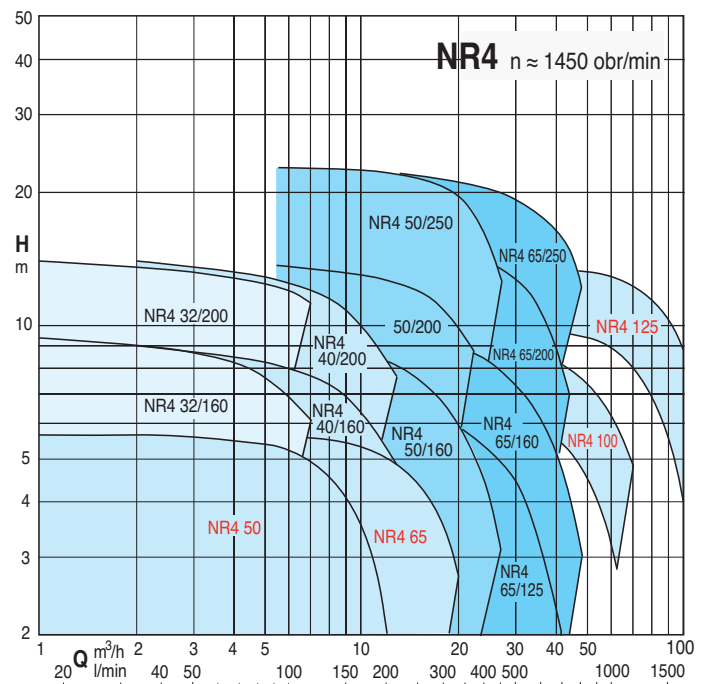
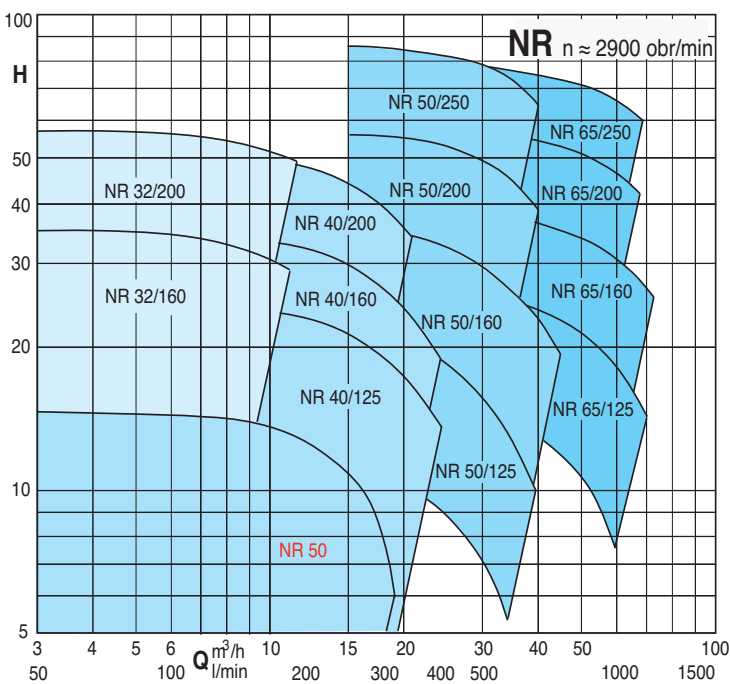

Wykresy charakterystyk $n \approx 2900$ obr/min

5

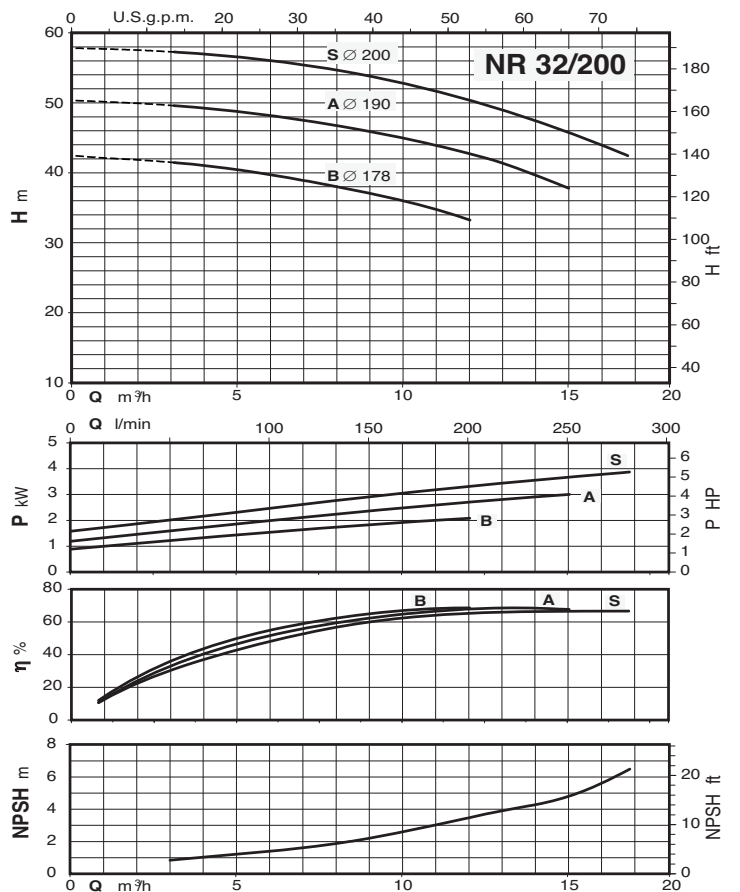
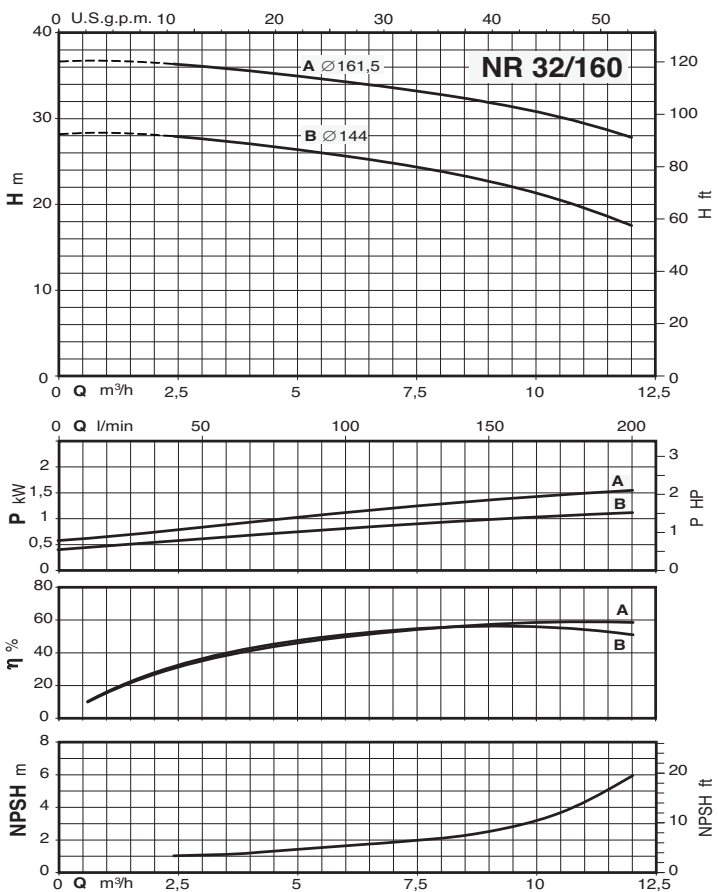
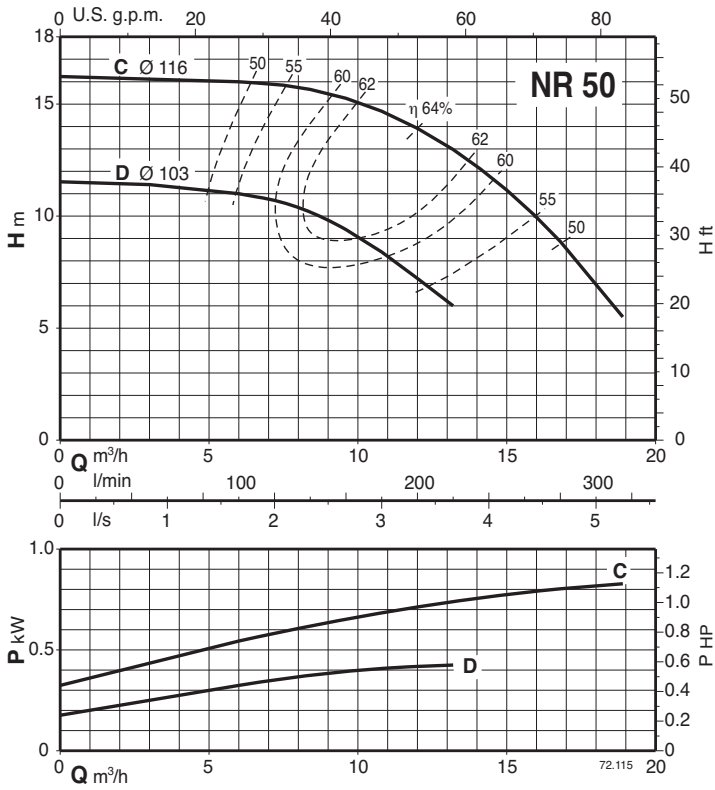

Wykresy charakterystyk $n \approx 2900$ obr/min

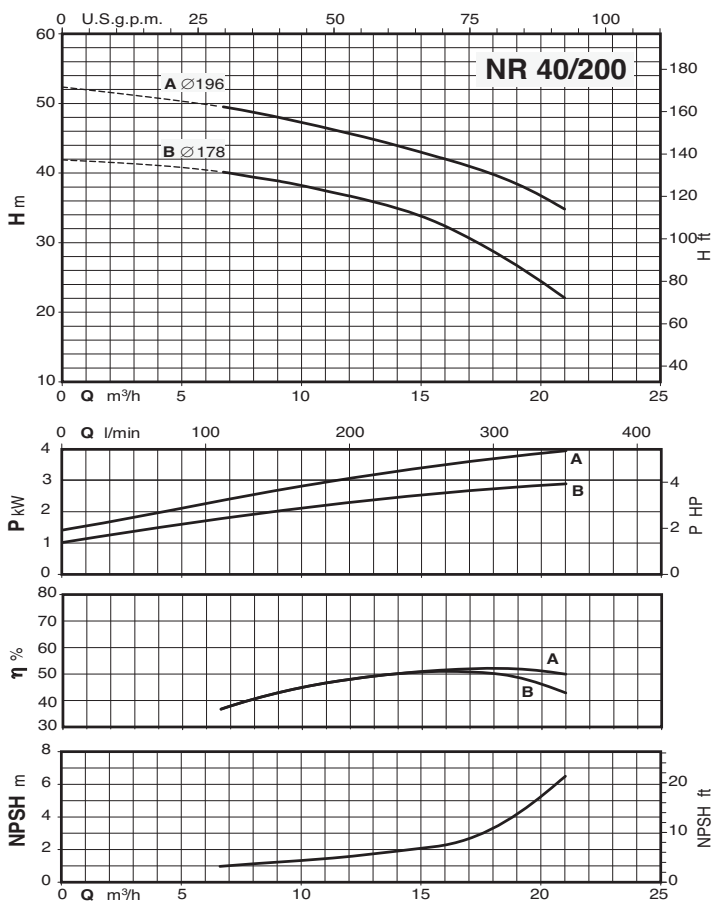
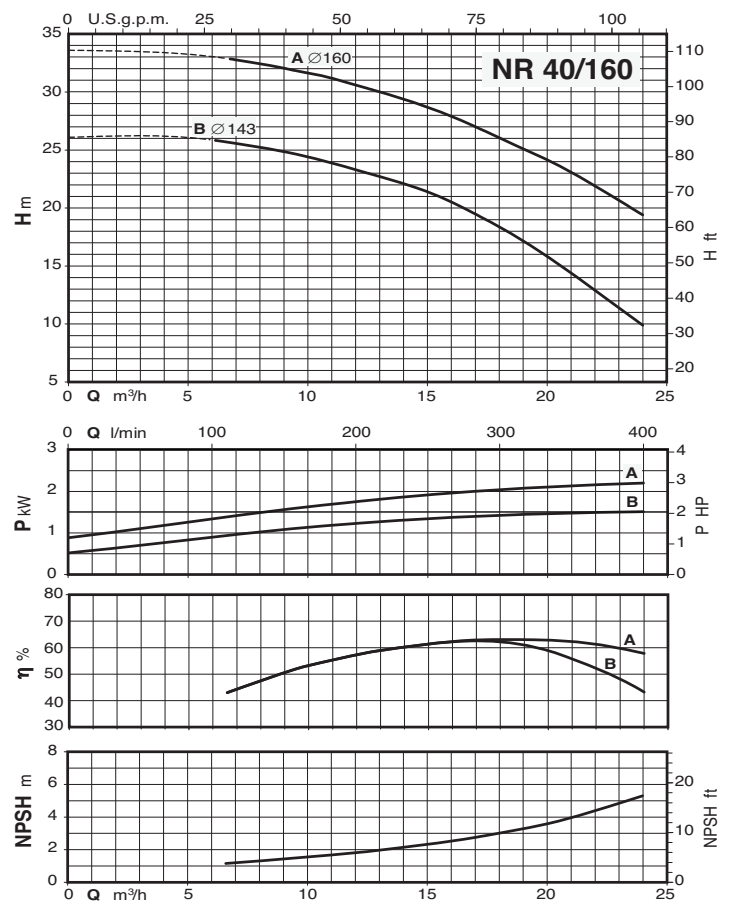
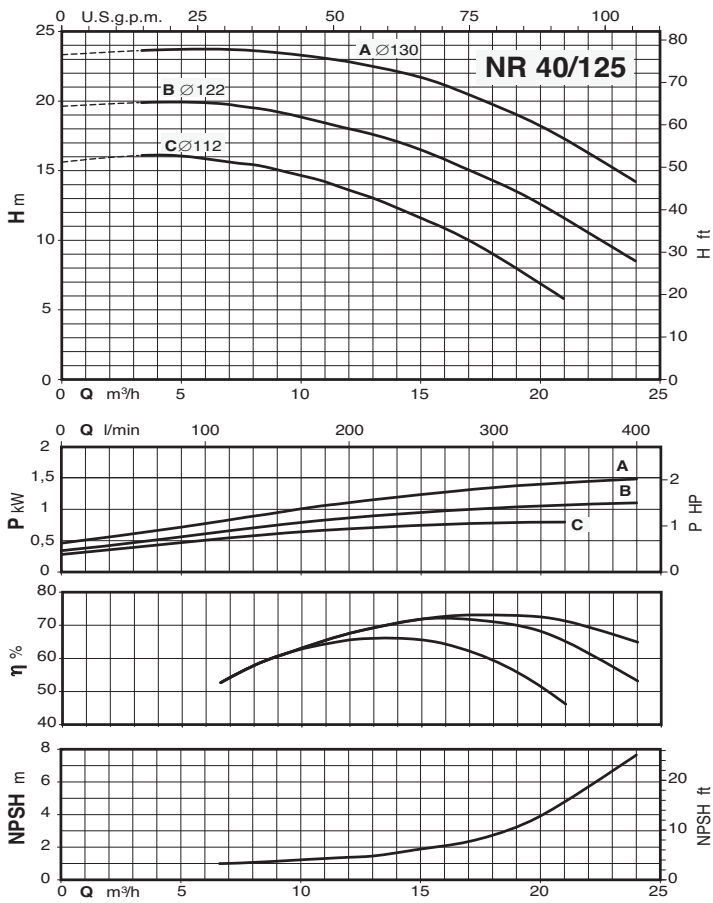

Wykresy charakterystyk $n \approx 2900$ obr/min

5

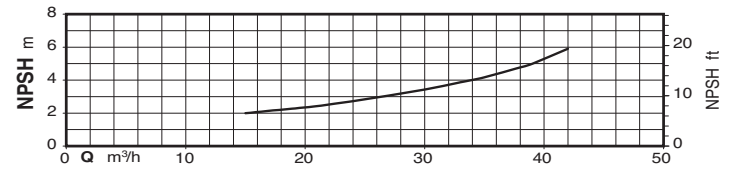
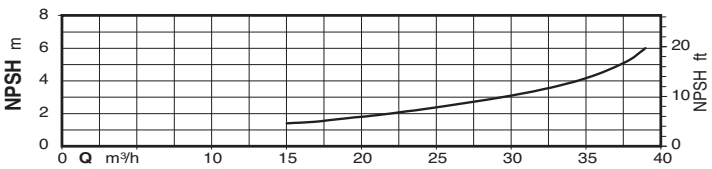
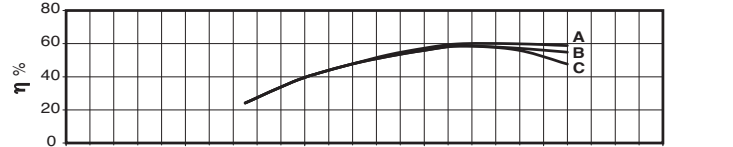
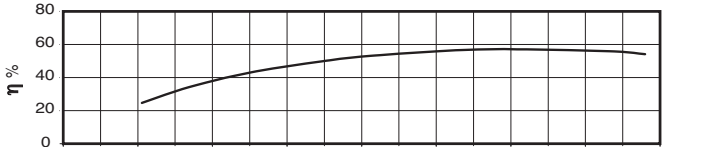
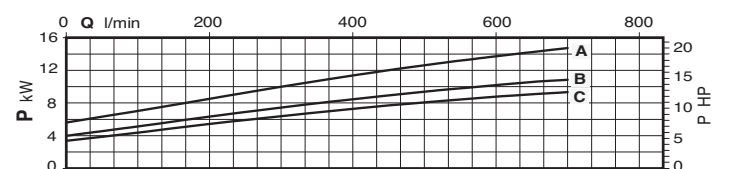
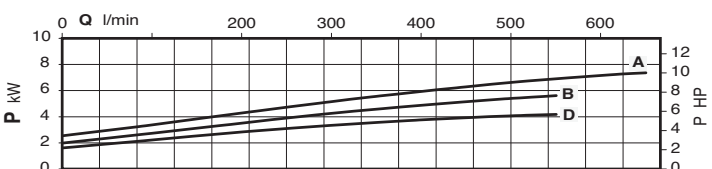
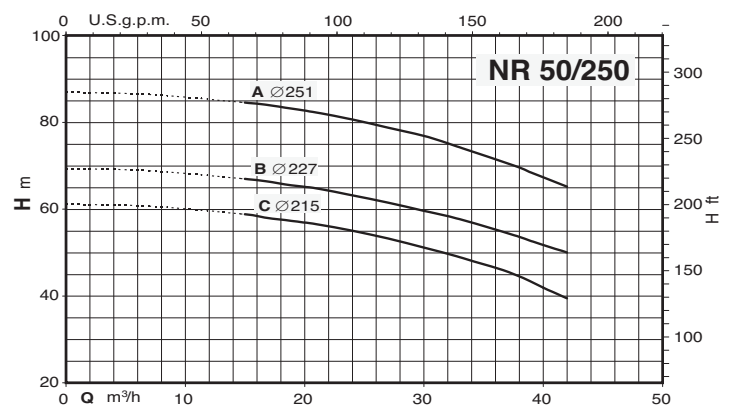
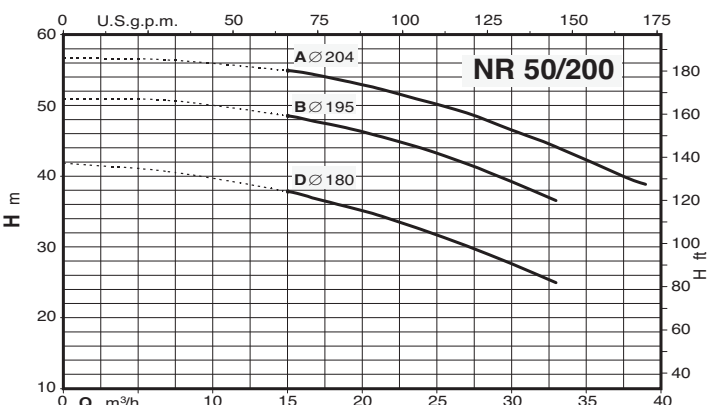
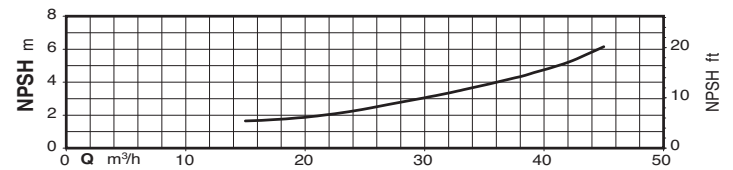
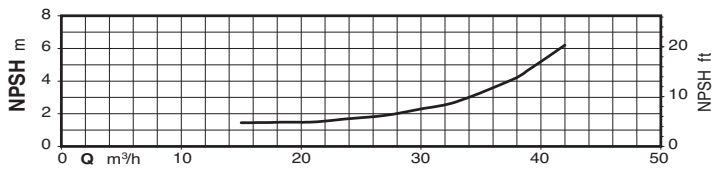
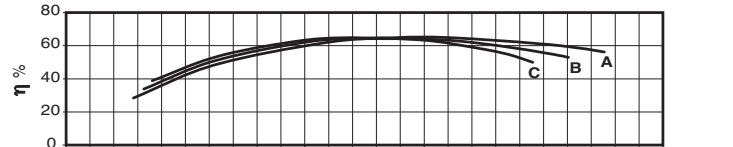
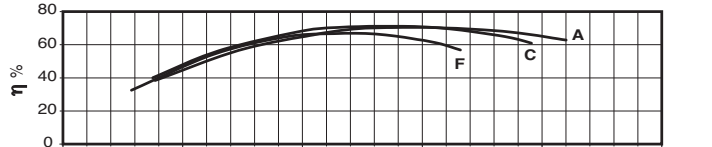
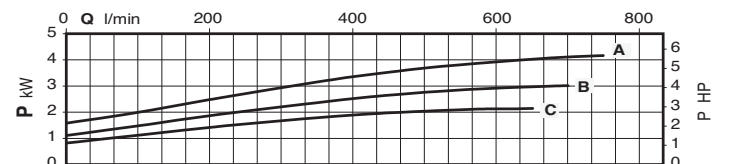
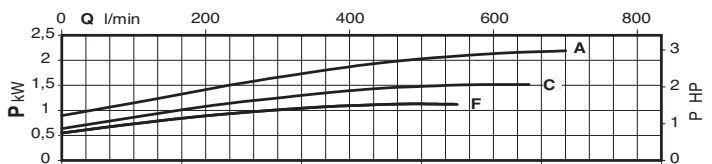
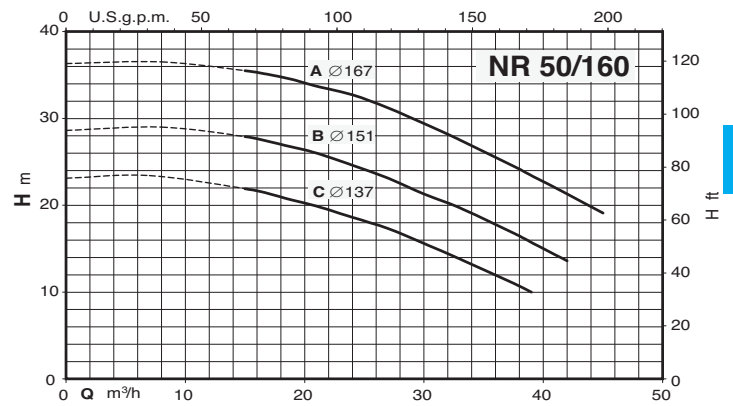
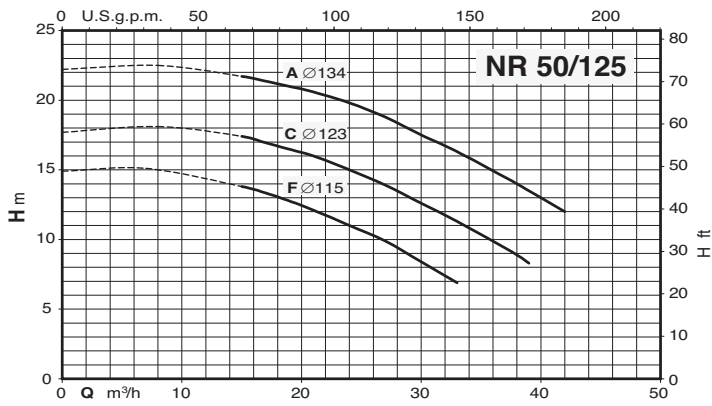

Wykresy charakterystyk $n \approx 2900$ obr/min

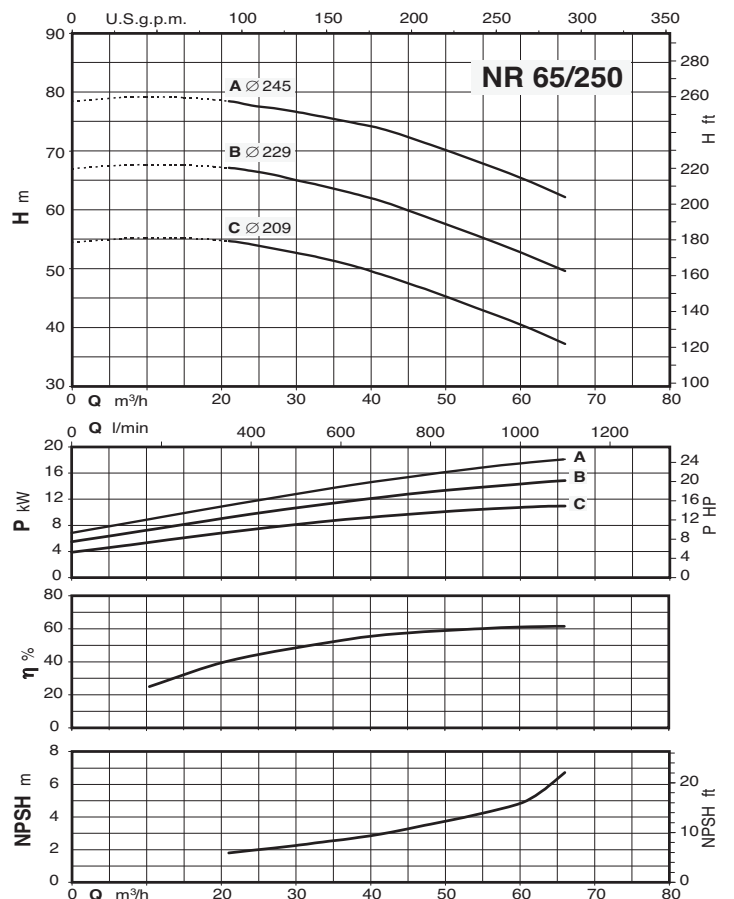
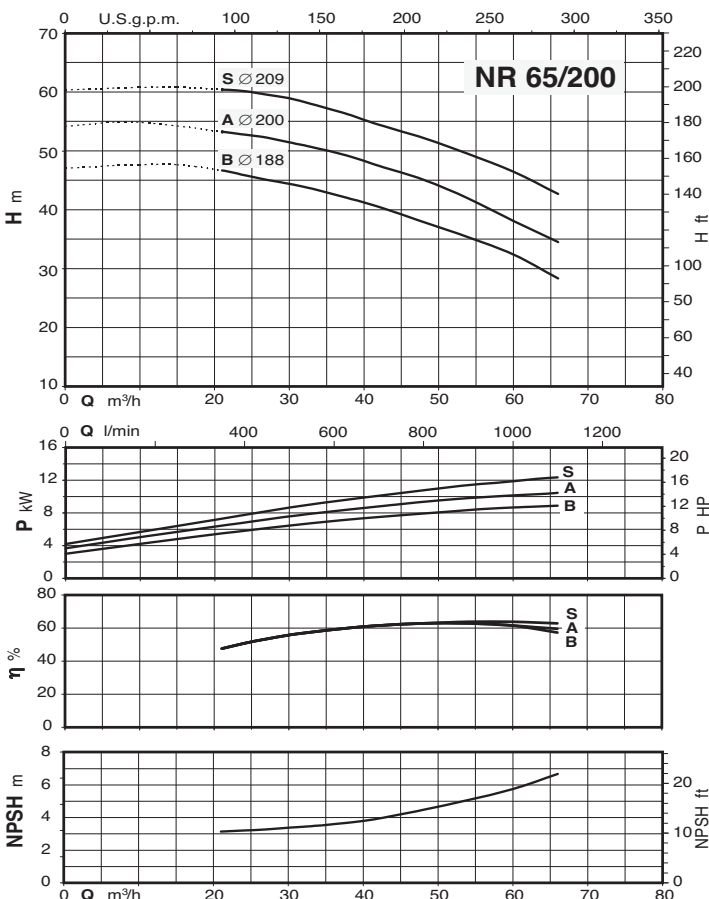
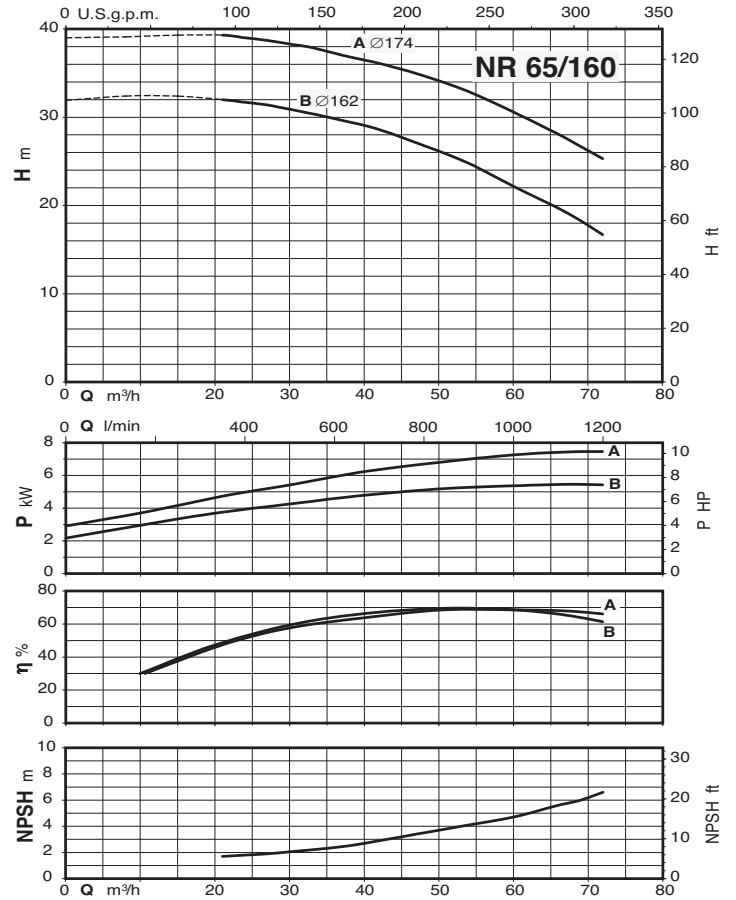
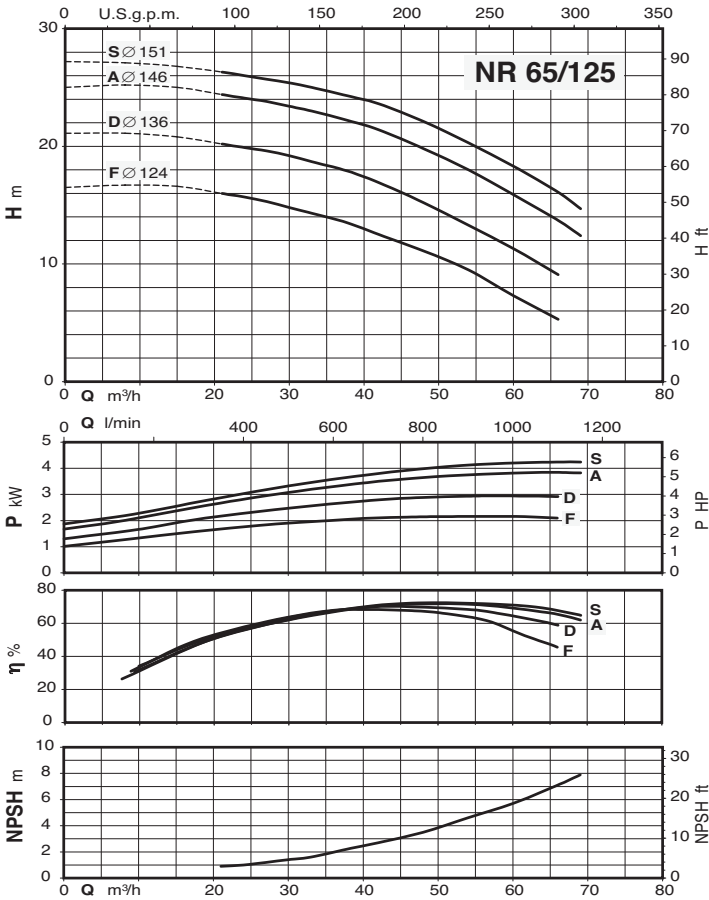

Wykresy charakterystyk $n \approx 1450$ obr/min

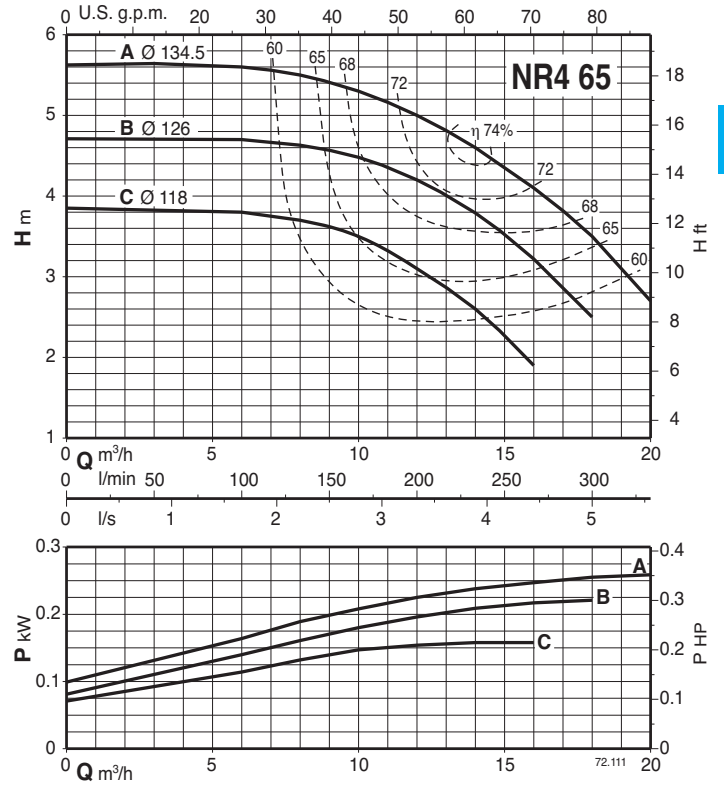
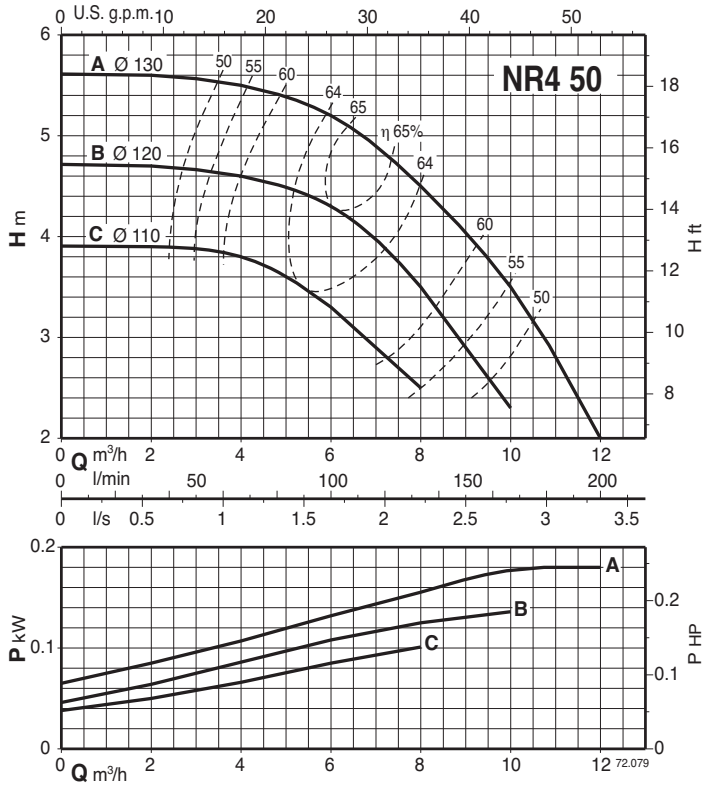

Wykresy charakterystyk $n \approx 1450$ obr/min

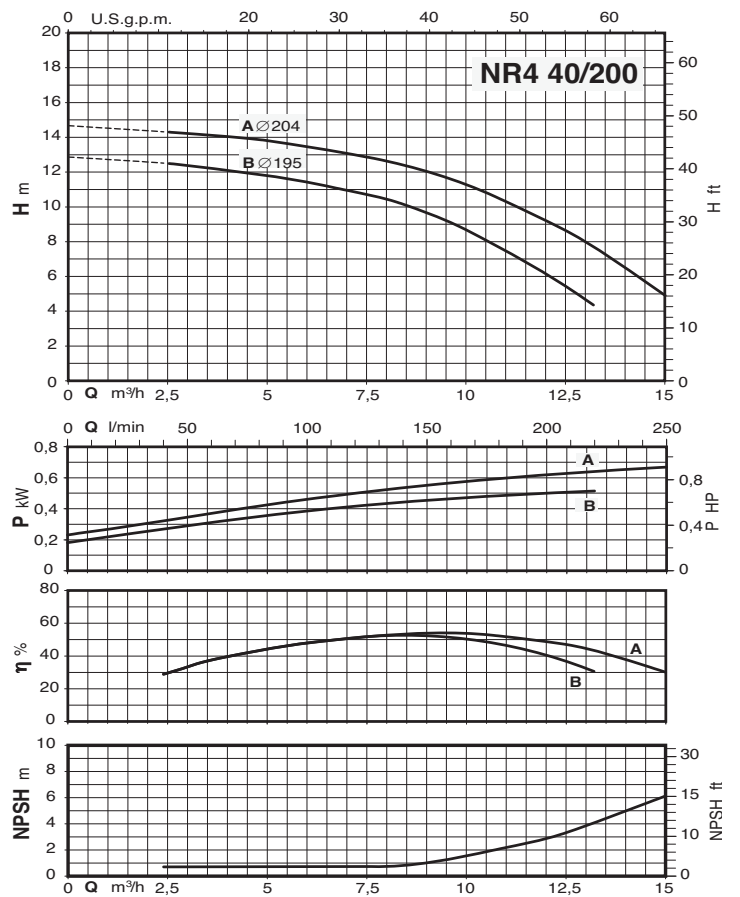
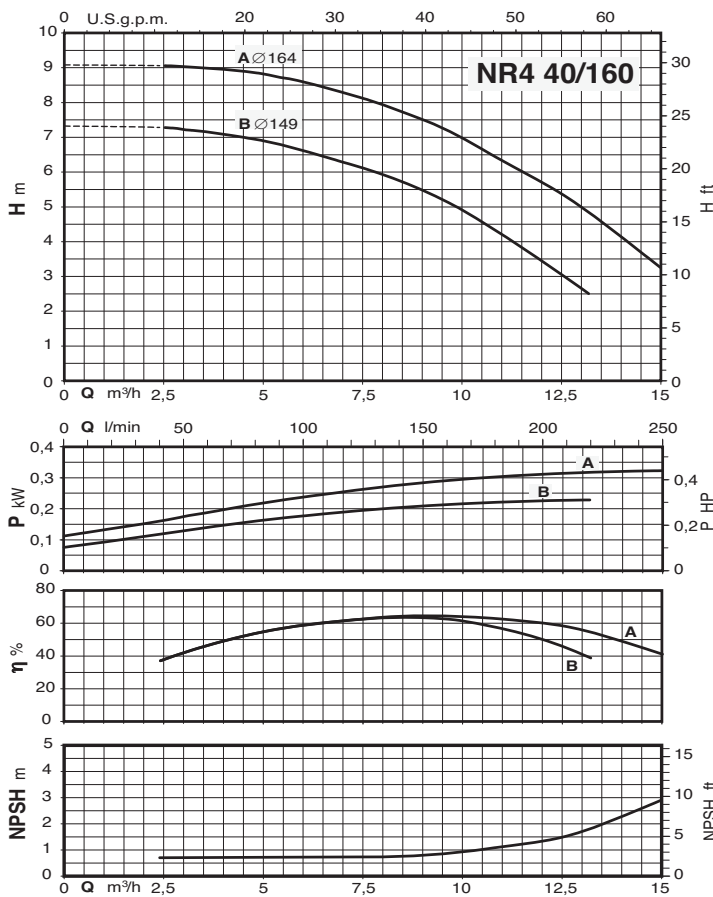
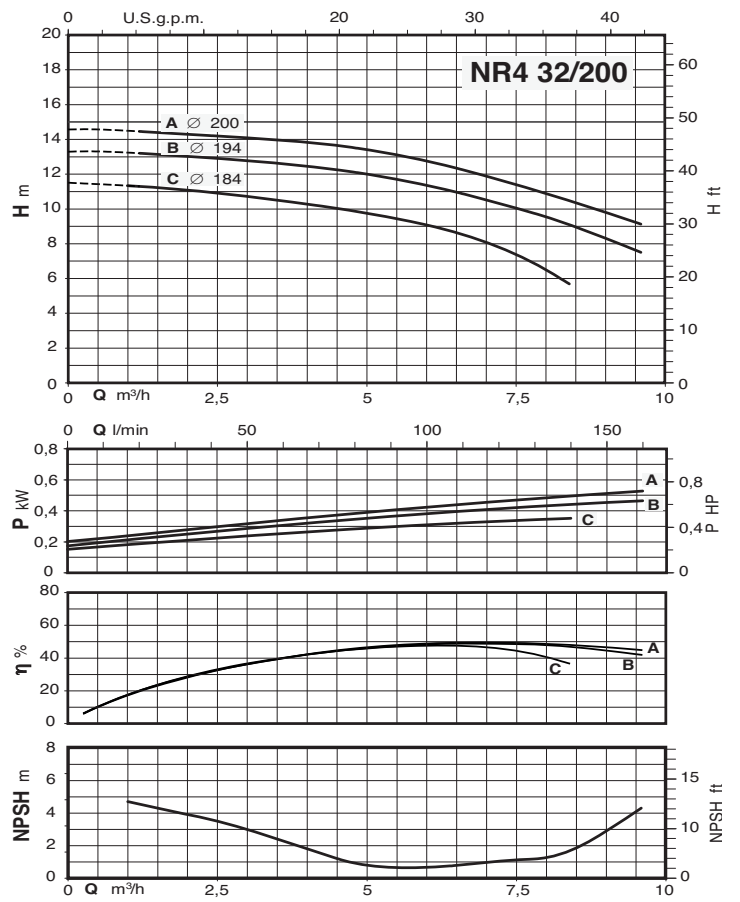
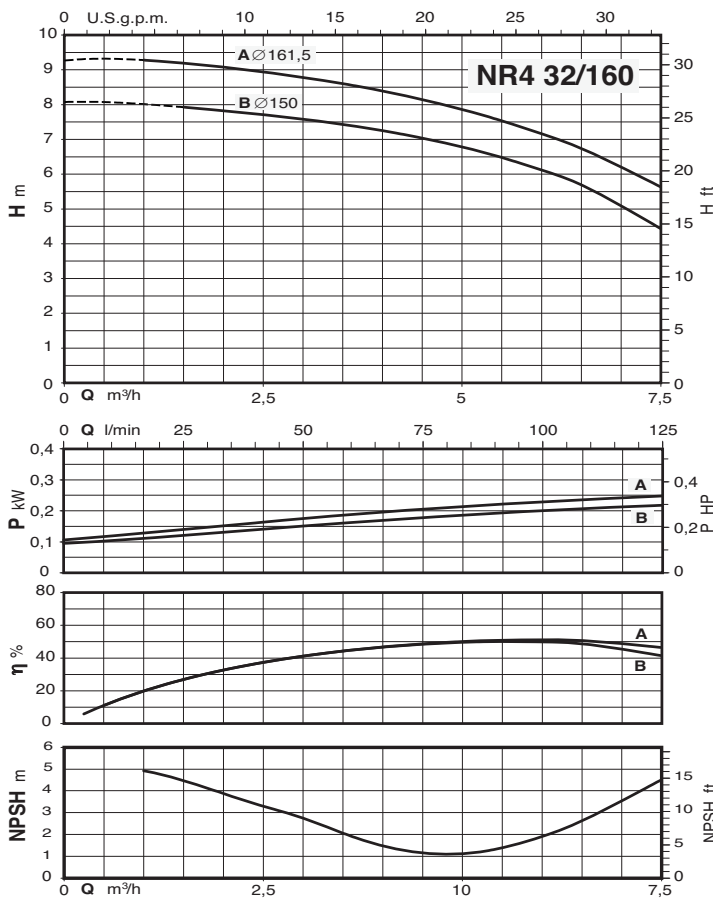

Wykresy charakterystyk $n \approx 1450$ obr/min

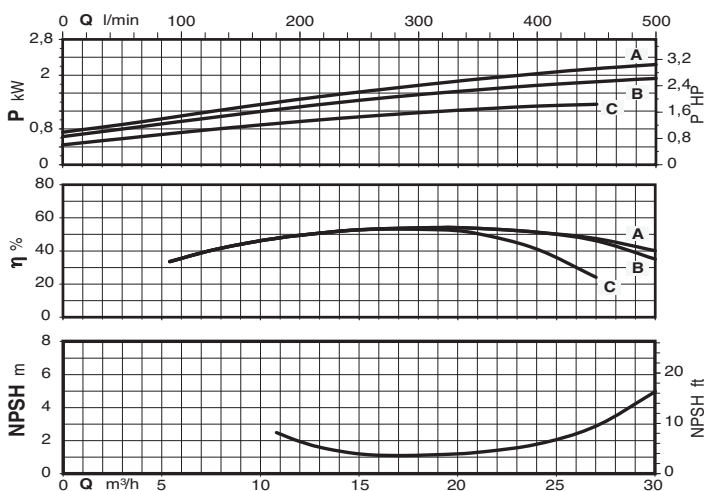
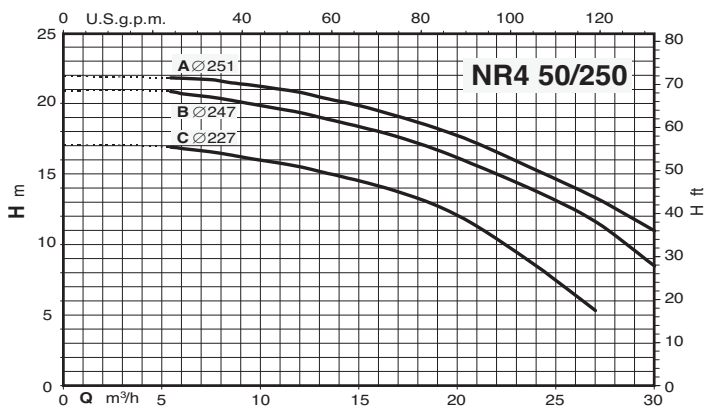
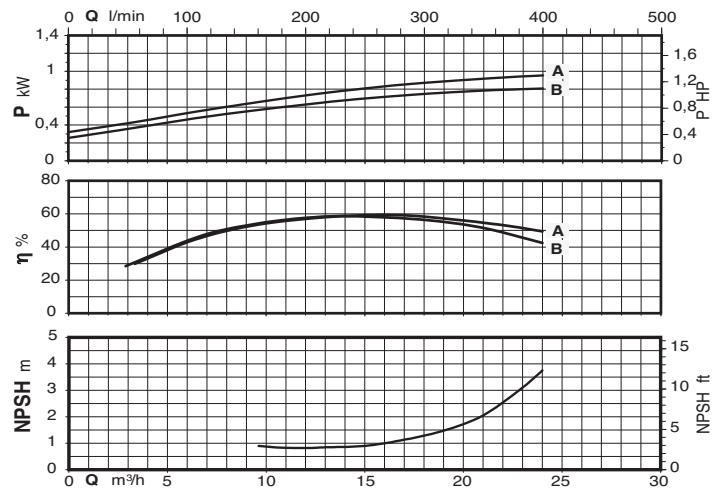
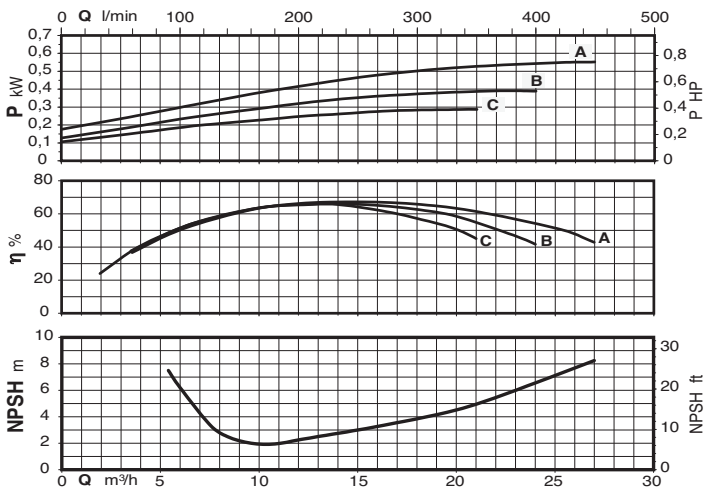
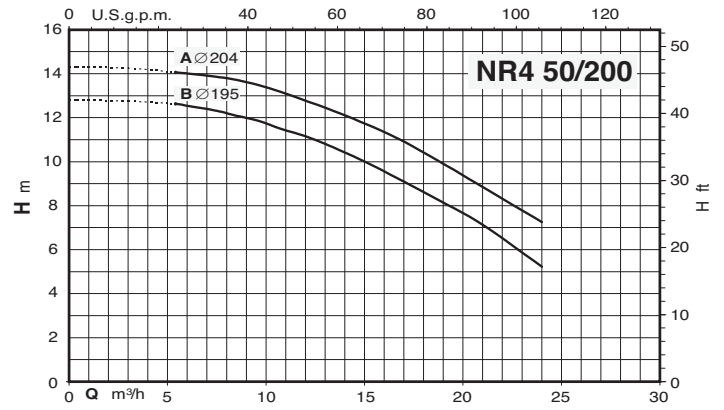
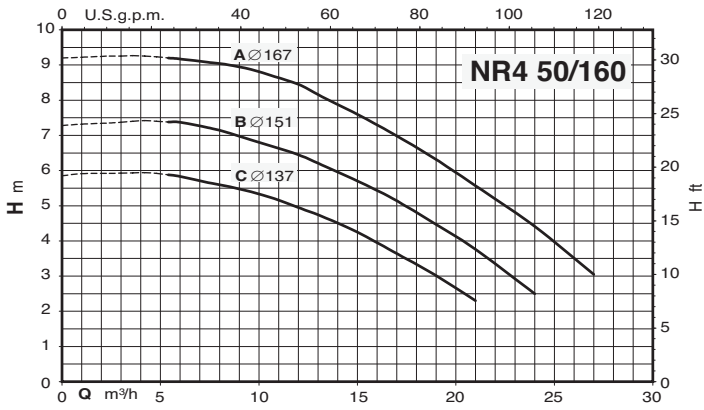

Wykresy charakterystyk $n \approx 1450$ obr/min

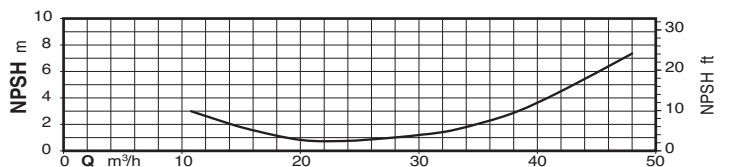
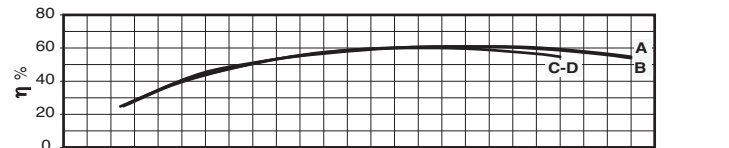
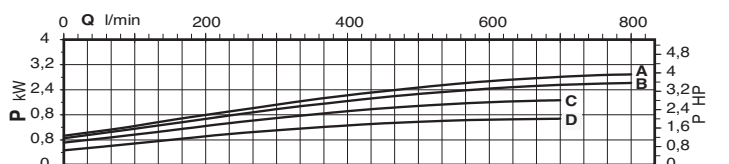
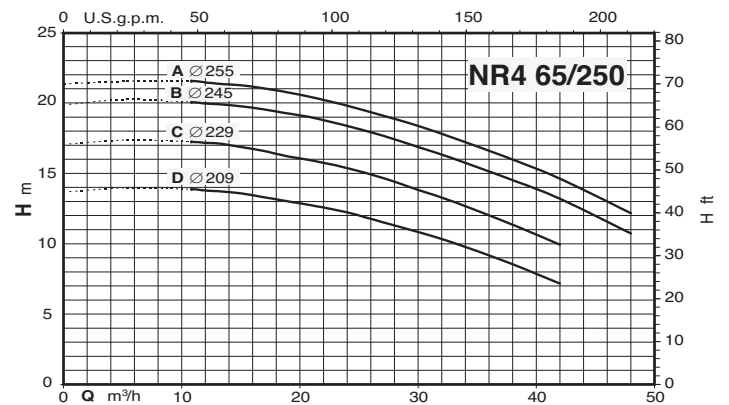
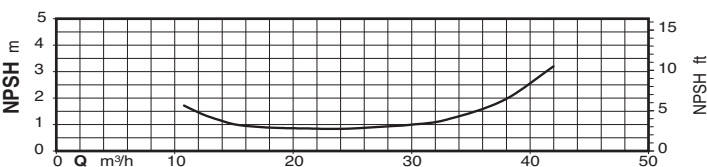
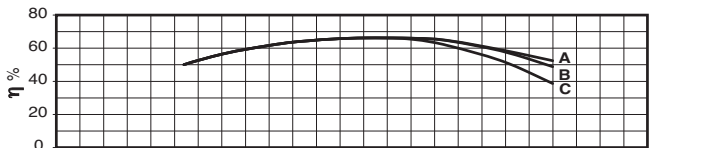
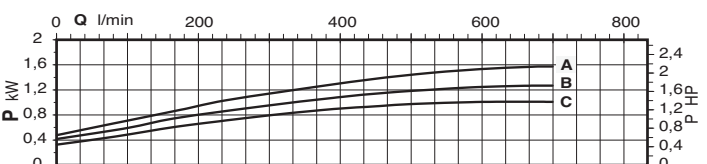
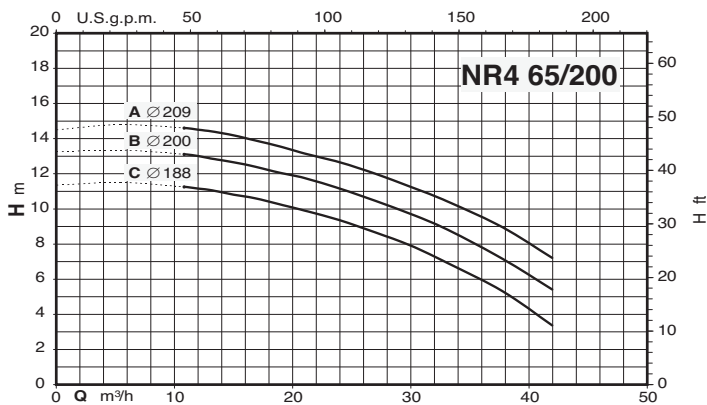
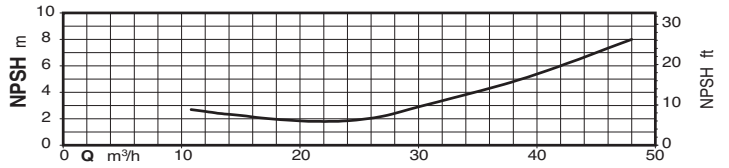
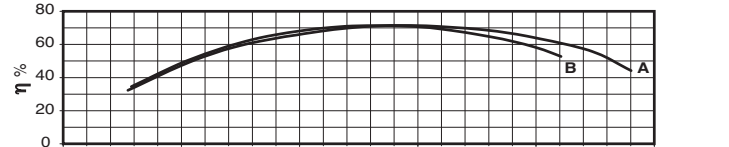
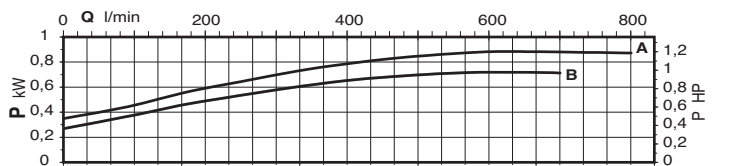
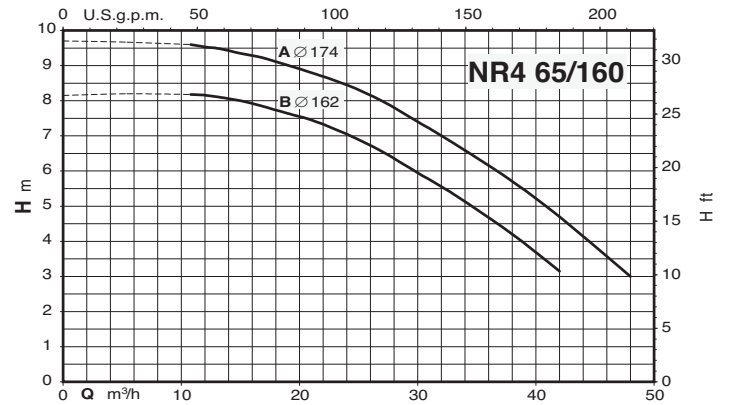
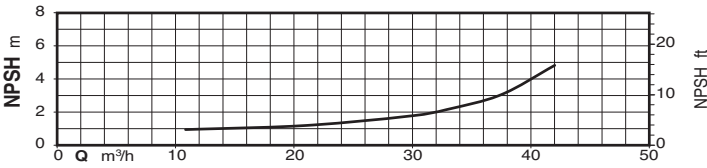
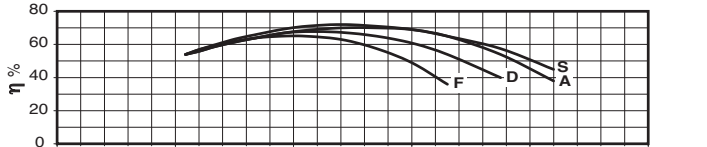
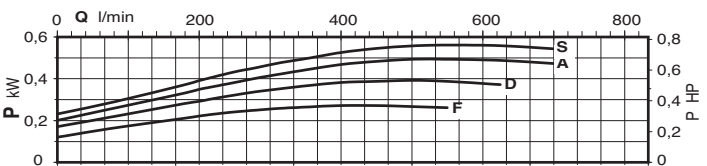
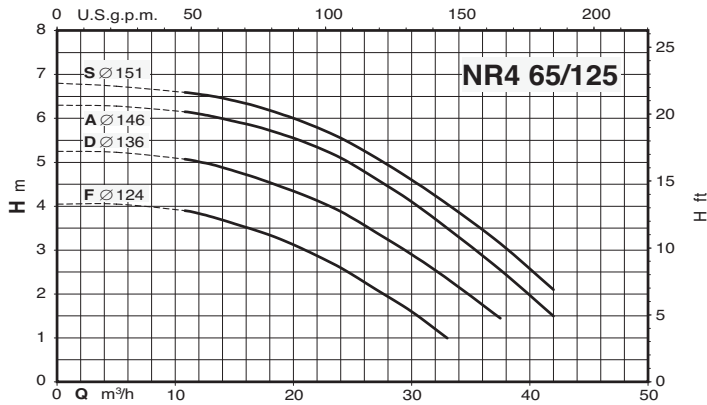

Wykresy charakterystyk $n \approx 1450$ obr/min

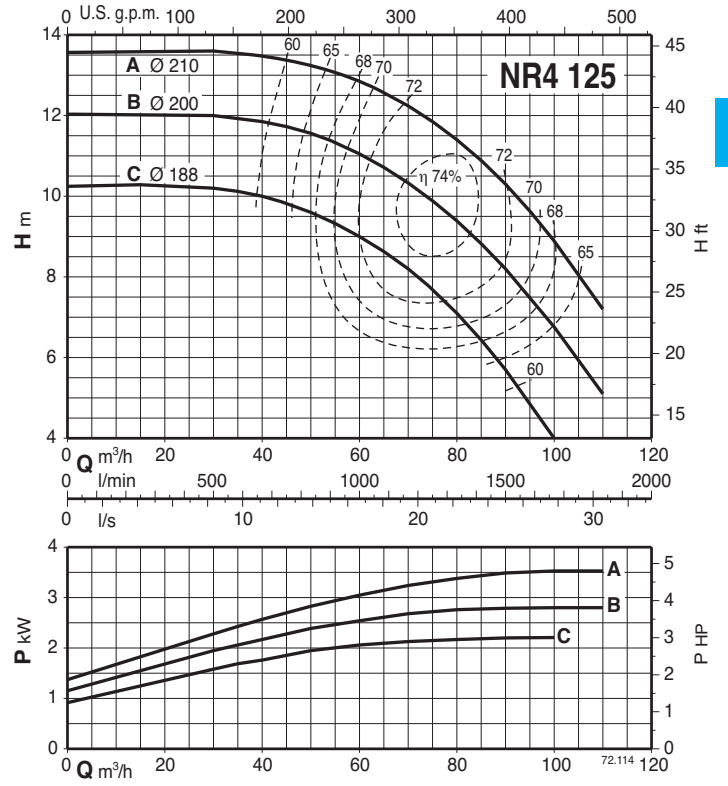
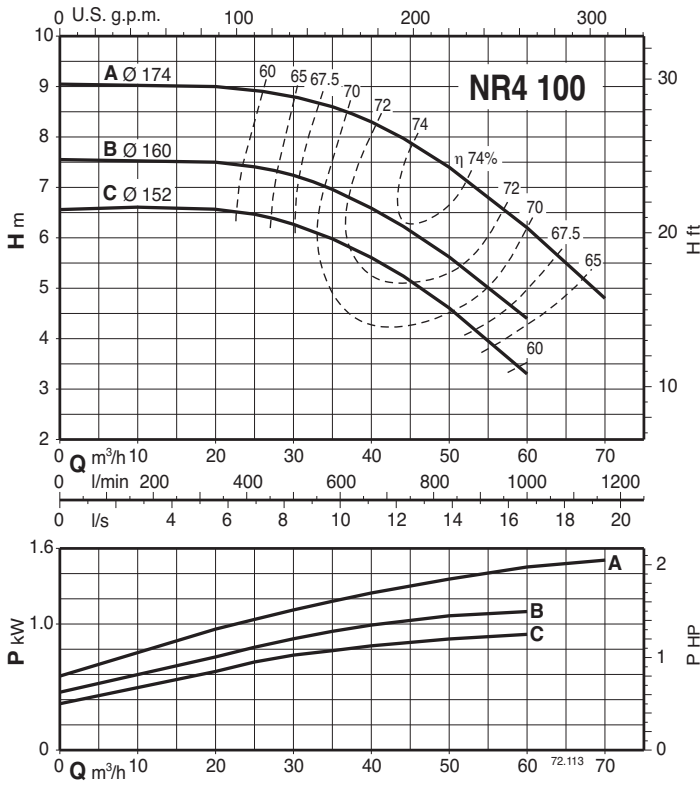

5

Wymiary i waga

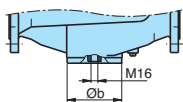
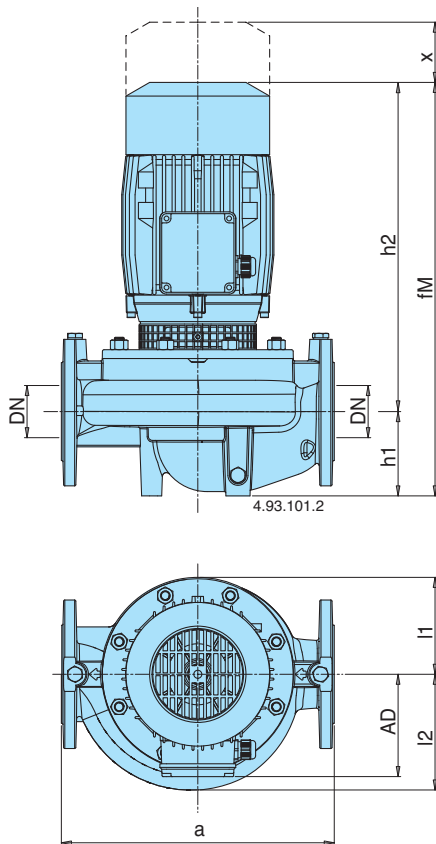

Kolnierze PN 10, EN 1092-2

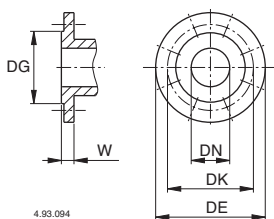

DN	mm					W
	DG	DK	DE	Otwory N°	Ø	
32	76	100	140	4	19	18
40	84	110	150	4	19	18
50	99	125	165	4	19	20
65	118	145	185	4	19	20
80	132	160	200	8	19	22
100	156	180	220	8	19	24
125	184	210	250	8	19	24

TYP	mm										kg
	DN	a	fM	h1	h2	Øb	AD	l1	l2	x	
NR 50D/A-C/B	50	320	360	90	270	98	111	93	100	70	29,5-30,8
NR 32/160A/A-B/A	32	340	421	80	341	-	128	102	102	60	
NR 32/200B	32	440	469	85	384	-	128	126	126	60	- 36,3
NR 32/200A/A-S/A	32	440	495	85	410	-	138	126	126	60	
NR 40/125A/A-B/A-C	40	320	420	81	339	-	128	93	98	70	29,5-27,5-26,5
NR 40/160B/A	40	320	430	81	349	-	128	119	119	75	35,0
NR 40/160A/A	40	320	470	81	389	-	128	119	119	75	40,0
NR 40/200A/A-B	40	440	496	81	430	-	138	140	140	75	57,5 - 57
NR 50/125C/A-F/A	50	340	437	90	347	-	128	96	115	75	31,5-29,5
NR 50/125A/B	50	340	477	90	387	-	128	96	115	75	36,1
NR 50/160C/B	50	340	480	90	390	-	128	120	128	75	41,6
NR 50/160A/B-B/A	50	340	506	90	416	-	138	120	128	75	51,8-50,5
NR 50/200D/B	50	440	516	100	416	-	138	140	140	80	59,7
NR 50/200A/A-B/A	50	440	544	100	444	-	160	140	140	80	77,2-69,7
NR 50/250C/B	50	440	657	100	557	-	185	175	175	85	114
NR 50/250B/B	50	440	707	100	557	-	185	175	175	85	121
NR 50/250A/B	50	440	732	100	632	-	185	175	175	85	149,5
NR 65/125F/B	65	340	494	105	389	-	128	121	145	95	46
NR 65/125S/B-A/B-D/A	65	340	520	105	415	-	138	121	145	95	56,1-56,1-54,6
NR 65/160A/A-B/A	65	340	552	105	447	-	160	121	142	95	74-67,5
NR 65/200B/B	65	475	666	105	561	-	185	140	153	90	108
NR 65/200A/B	65	475	716	105	611	-	185	140	153	90	114
NR 65/200S/B	65	475	741	105	636	-	185	140	153	90	142,5
NR 65/250C/B	65	475	722	105	567	-	185	175	175	90	134
NR 65/250A/B-B/B	65	475	747	105	642	-	185	175	175	90	161-155

TYP	mm										kg
	DN	a	fM	h1	h2	Øb	AD	l1	l2	x	
NR4 50A/A-B/A-C/A	50	320	360	90	270	98	111	93	100	70	24-24-24
NR4 65A/A-B/A-C/A	65	360	370	100	270	118	111	102	114	70	28-28-28
NR4 100A/B-B/B-C/B	100	500	549	150	399	162	138	153	173	105	67-59-59
NR4 125C/B	125	600	589	170	419	194	138	172	195	120	91,5
NR4 125A/A-B/A	125	600	608	160	438	194	160	172	195	120	110-108
NR4 32/160A-B	32	340	421	80	341	-	128	102	102	60	23-22,9
NR4 32/200B-C	32	440	429	85	344	-	128	126	126	60	
NR4 32/200A/A	32	440	469	85	344	-	128	126	126	60	
NR4 40/160A-B	40	320	430	81	349	-	128	119	119	75	31,5 - 31
NR4 40/200B	40	440	430	81	349	-	128	140	140	75	39,5
NR4 40/200A/A	50	440	470	81	349	-	128	140	140	75	43
NR4 50/160B-C	50	340	440	90	350	-	128	120	128	75	35,5-33,5
NR4 50/160A/B	50	340	480	90	350	-	128	120	128	75	37,5
NR4 50/200A/B-B/B	50	440	516	100	416	-	138	140	140	80	56
NR4 50/250C/B	50	440	516	100	416	-	138	175	175	85	77,5
NR4 50/250A/A-B/B	50	440	545	100	445	-	160	175	175	85	93,5-80
NR4 65/125D-F	65	340	454	105	349	-	128	121	145	95	39-37
NR4 65/125S/B-A/B	65	340	494	105	349	-	128	121	145	95	42-41,5
NR4 65/160A/B-B/B	65	340	504	105	399	-	138	121	142	95	42,7-42,5
NR4 65/200C/B	65	475	536	105	431	-	138	140	153	90	52
NR4 65/200B/B	65	475	536	105	431	-	138	140	153	90	60
NR4 65/200A/B	65	475	552	105	447	-	160	140	153	90	64,5
NR4 65/250C/B-D/B	65	475	555	105	450	-	160	175	175	90	75,5-75,5
NR4 65/250A/A-B/A	65	475	555	105	450	-	160	175	175	90	98-85

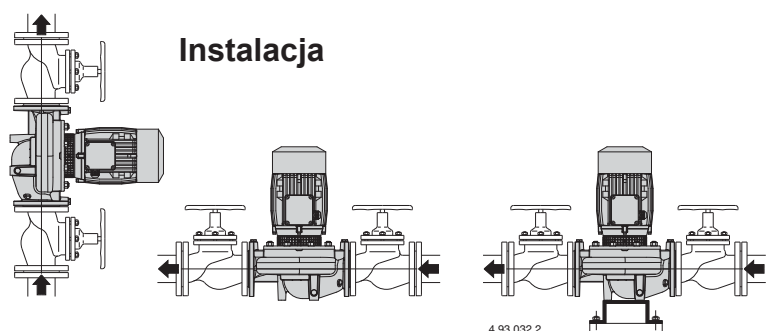

Widok w przekroju

